

SLT 3187 – 22.5 x 13.00"

Forged light alloy wheels for commercial vehicles and buses

Truck
speedline



- ▶ Payload of 5800 kg
- ▶ Bolt hole diameter 26 and 32 mm
- ▶ Diamond surface
- ▶ Particular corrosion protection at the valve

Wheels developed for the mounting of tubeless tires.

Wheel size	Wheel code	Surface finish	Bolt hole Ø (mm)	ET (mm)	Max. payload (kg)	Average weight (kg)	Centre bore Ø (mm)	Mounting hole PCD Ø (mm)	Number mounting holes	Disk thickness (mm)
22.5 x 13.00"	SLT 3187 AM	Diamond	26	-14	5800	27.9	281	335	10	28.0
	SLT 3187 BM	Diamond	32							

Light wheels for heavy weights

ABE-TÜV:**APPROVED TIRE SIZES:****VALVE:****LOCKING TORQUE OF THE VALVE:****MAXIMUM TYRE PRESSURE:****APPROVED BALANCE WEIGHTS:****STUD TORQUE WHEEL NUT:**

KBA 49687

e.g. 425/65 R22.5, 445/65 R22.5

SPEEDLINE TRUCK article number: SLT-020

3 - 5 Nm

11 bar or the lower value recommended by the tire producer

Clip-on and adhesive weights for alloy wheels for commercial vehicles

600 – 680 Nm

For wheel nuts M22 x 1.5, 7/8"-11 BSF, 7/8"-14 UNF

SLT 3187: Mounting Instructions

Mounting Type A

The SPEEDLINE TRUCK forged light alloy wheels can be mounted according to the „M“ system (see picture A), following the ISO standard 4107. Prior to mounting it is required to check if the vehicle is equipped for the mounting of light alloy wheels SLT 3187, as these wheels have a larger flange thickness than steel wheels.

It is important to assure that:

1. the base on the hub measures at least 10 mm.
2. the length of the studs from the hub flange corresponds at least to the sum of the nut length and the wheel flange thickness - according to DIN 74361, part 3.

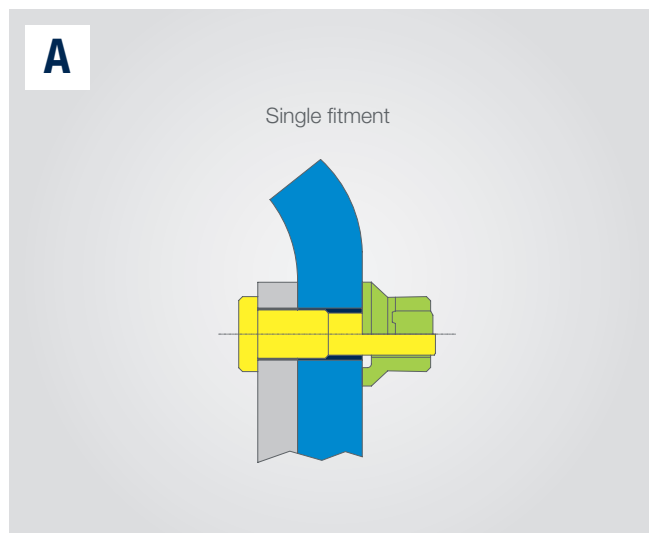

Mounting Type B

If a vehicle is not equipped for the mounting of light alloy wheels or the user wants to avoid to substitute the bolts then, as an alternative, the following solution may be applied (see picture B):

1. Shank nuts M22 x 1.5, 7/8"-11 BSF, 7/8"-14 UNF.
2. Wheels with larger bolt holes (B = Ø 32 mm)

both approved by TÜV.

By the use of the extended thread of the shank nut, optimised and precise fitting will be achieved.

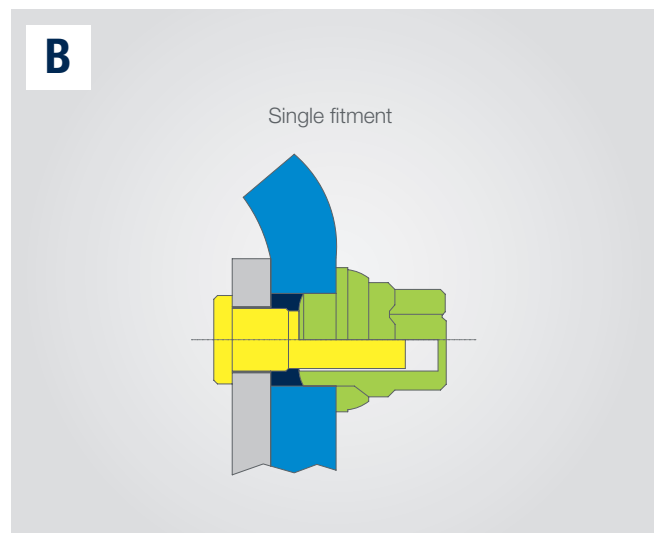

Please pay attention to ensure the appropriate number of turns between shank nut and stud:

13 for M22 x 1.5 (approx. 20 mm), 8 for 7/8"-11 BSF (approx. 19 mm), 12 for 7/8"-14 UNF (approx. 22 mm).

Advice

Forged SPEEDLINE TRUCK light alloy wheels are not lacquered, manufactured out of highly corrosion resistant alloy T6061.

All forged SPEEDLINE TRUCK light alloy wheels are warranted for 5 years from the manufacturing date without mileage limitation.

www.speedline-truck.com

All information is subject to change. SPEEDLINE TRUCK reserves the right for changes in design and in technical characteristics.

The wheel designs and the content of this product information are protected by copyright.

Release 1.0, April 2014