

# SLT 3086 – 17.5 x 6.75", 10 bolt holes

Forged light alloy wheels for commercial vehicles and buses

*Truck*  
**speedline**



▶ Payload of 3000 kg

▶ Diamond surface

▶ Bolt hole diameter 26 mm

▶ Particular corrosion protection at the valve

Wheels developed for the mounting of tubeless tires.

Wheel size	Wheel code	Surface finish	Bolt hole Ø (mm)	ET (mm)	Max. payload (kg)	Average weight (kg)	Centre bore Ø (mm)	Mounting hole PCD Ø (mm)	Number mounting holes	Disk thickness (mm)
17.5 x 6.75"	SLT 3086 AM	Diamond	26	117	3000	14.6	176	225	10	22.0

*Light wheels for heavy weights*

**ABE-TÜV:****APPROVED TIRE SIZES:****VALVE:****LOCKING TORQUE OF THE VALVE:****MAXIMUM TYRE PRESSURE:****APPROVED BALANCE WEIGHTS:****STUD TORQUE WHEEL NUT:**

KBA 48650

e.g. 225/70 R17.5, 245/70 R17.5, 215/75 R17.5, 225/75 R17.5,  
235/75 R17.5, 245/75 R17.5, 9.5 R17.5, 10 R17.5

Speedline Truck article number: 683.6010.004

3 - 5 Nm

8.5 bar or the lower value recommended by the tire producer

Clip-on and adhesive weights for alloy wheels for commercial vehicles

600 – 680 Nm

or the value for shank nuts M22 x 1.5 recommended  
by the vehicle producer

## SLT 3086: Mounting instructions

The Speedline Truck forged light alloy wheels can be mounted according to the „M“ system (see picture), following the ISO standard 4107. Prior to mounting it is required to check if the vehicle is equipped for the mounting of light alloy wheels SLT 3086, as these wheels have a larger flange thickness than steel wheels.

It is important to assure that:

1. the base on the hub measures at least 8 mm for single fitment and 26 mm for twin fitment.
2. the length of the studs from the hub flange corresponds at least to the sum of the nut length and the wheel flange thickness  $\cdot$  2 wheels flange thicknesses with twin fitment - according to DIN 74361, part 3.

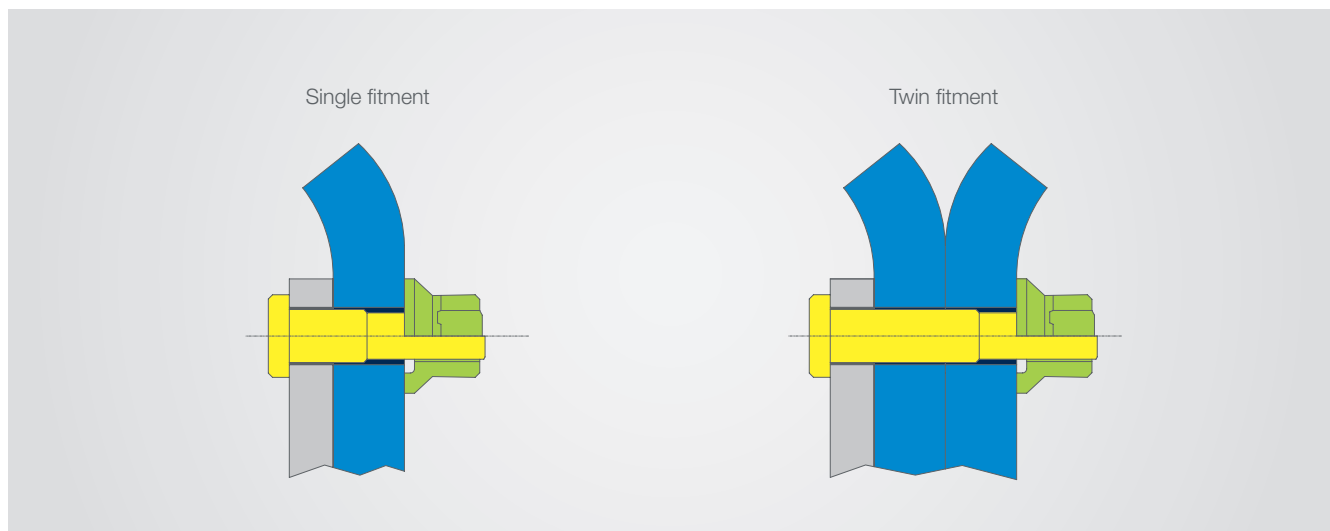

Please pay attention to ensure the appropriate number of turns between shank nut and stud:  
13 for M22 x 1.5 (approx. 20 mm).

**Advice**

Forged Speedline Truck light alloy wheels are not lacquered, manufactured out of highly corrosion resistant alloy T6061.

**All forged Speedline Truck light alloy wheels are warranted for 5 years from the manufacturing date without mileage limitation.**

[www.speedline-truck.com](http://www.speedline-truck.com)

All information is subject to change. Speedline Truck reserves the right for changes in design and in technical characteristics.

The wheel designs and the content of this product information are protected by copyright.

Release 3.0, Jan. 2013